

Step 4:

Insert leg assembly into gussets as indicated. (Figure 4)

Tighten all set screws.

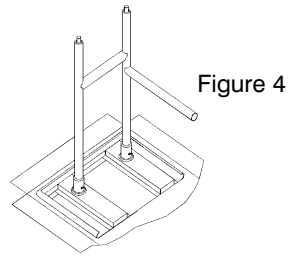

FINAL STEP

Turn table upright and level by adjusting bullet feet.

UNDERSHELF

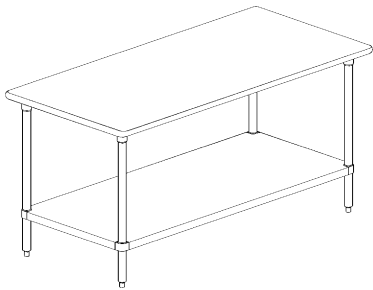

**OPEN BASE
(Rear Brace Shown)**

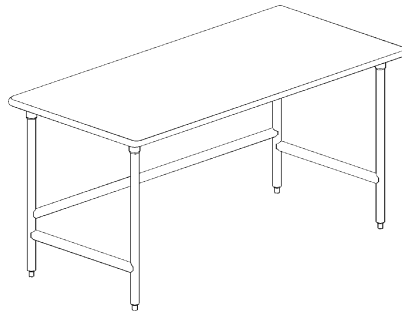

Please Follow same Installation Instructions for Tables with 5" Back Splash

For Questions on Installation,
Please call our Customer Service Department at:
866-799-0106
or email us at:
info@alinebyadvancetabco.com



200 Heartland Boulevard, Edgewood, NY 11717-8380

© ADVANCE TABCO, April 2008



Installation Instructions for Professional Chef Tables



Counter Top Edge



Bull Nose Edge



Wood Top

**CHECK FOR CONCEALED DAMAGE
FILE CLAIM WITH DELIVERING FREIGHT CARRIER**

Tables manufactured by **ADVANCE TABCO®** are designed and constructed for applications including Food Preparation, Cooking, Manufacturing, Material Handling, Laboratory Service and the like. **ADVANCE TABCO®** does not recommend product use for activities employing harsh and active chemicals. Consult factory regarding unusual applications.

TABLES with Undershef

This package contains Table Top, Undershef, Legs & Set Screws

Tool required for installation: 5/32 Allen wrench.

Step 1:

Lay the table top flat on the box to protect the finish during assembly. (Figure 1)

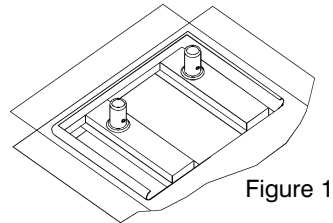

Figure 1

Step 2:

Remove plastic cap from gusset. (Figure 2) Set screws are located inside gusset.

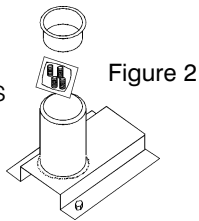

Figure 2

Step 3:

Insert set screws into adjustable shelf corner (underneath shelf). Insert legs into adjustable shelf corner and align with score marks on leg. Tighten set screws. (Figure 3) Shelf is adjustable.

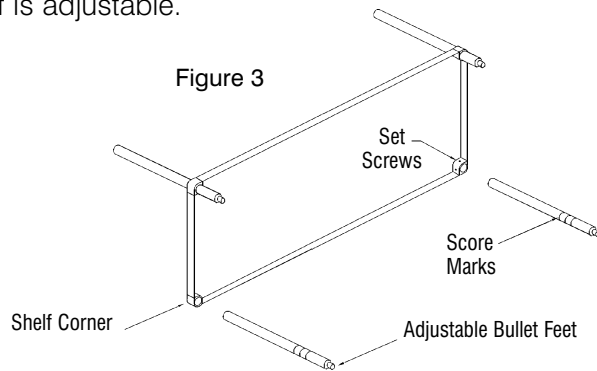

Figure 3

Step 4:

Insert legs and undershef assembly into gussets as indicated in Figure 4. Tighten set screws.

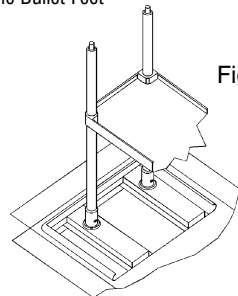

Figure 4

TABLES with Rear or Center Bar

This package contains Table Top, "H" Leg Assembly, and Cross Brace Assembly with Fasteners

Tools required for installation: 5/32 Allen wrench and 7/32 Allen wrench

Step 1:

Lay the table top flat on the box to protect the finish during assembly. (Figure 1)

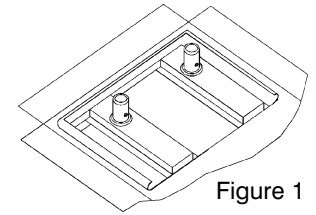

Figure 1

Step 2:

Remove plastic cap from gusset. (Figure 2) Set screws are located inside gusset.

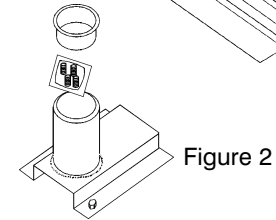

Figure 2

Step 3:

Align rear (Figure 3) or center (Figure 3a) cross brace with hole at rear of "H" leg assembly and fasten using 3/8" - 16 x 2-1/2" stainless steel button head socket bolt and tighten.

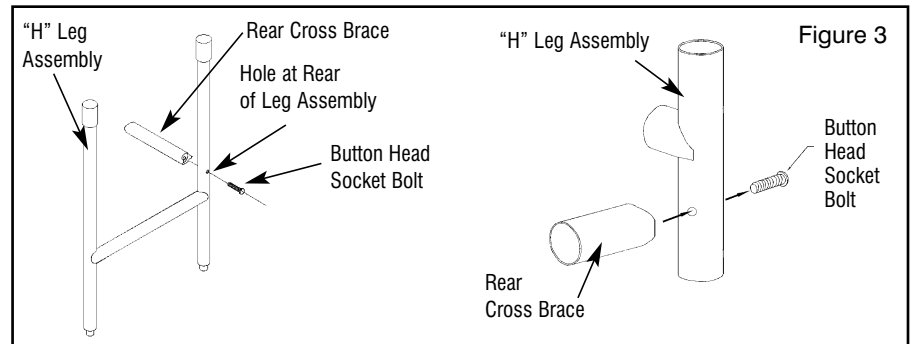

Figure 3

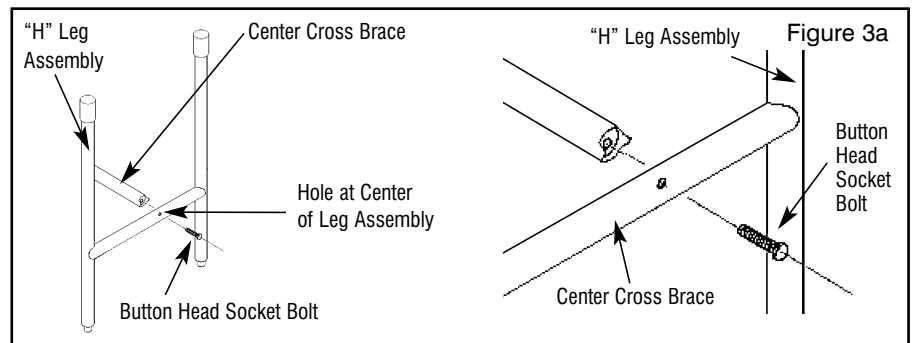

Figure 3a